

Fiber Optic LAN Components 1310nm SLED

HFE8500-020/XBA

FEATURES

- High coupled power, 30 μ W typical into 62.5/125 μ m fibre.
- 85MHz operating Bandwidth
- -40°C to + 85°C operating temperature
- Hermetically sealed package installed in industry standard ST housing
- High reliability



DESCRIPTION

The HFE8500-020/XBA is a high-performance InGaAsP surface emitting LED that offers high coupling powers in 1300nm fibre optic transmission applications. The LED is mounted in an industry standard low profile ST connector housing, optimised for low cost multi-mode systems where high bandwidth and long distance links are required.

APPLICATION

The HFE8500-020/XBA employs a high speed 1300nm SLED packaged in a TO-18 metal can and optically aligned within a low profile ST connector housing. Data rates can vary from DC to 85MHz depending upon component application. The LED is designed to convert electrical energy into optical output power that can be used in fibre optic communications and other applications.

The HFE8500-020/XBA is designed to be used with inexpensive silicon or gallium arsenide detectors in 1300nm multi-mode applications but can also be used in some single-mode systems.

Fiber Optic LAN Components

1310nm SLED

HFE8500-020/XBA

ABSOLUTE MAXIMUM RATINGS

Storage temperature	-55 to +125°C
Operating temperature	-40 to +85°C
Forward current	100 mA
Soldering temperature	+260 °C, 10 secs

NOTICE

Stresses greater than those listed under “Absolute Maximum Ratings” may cause permanent damage to the device. This is a stress rating only and functional operation of the device at these or any other conditions above those indicated in the operations section for extended periods of time may affect reliability.

ELECTRO-OPTICAL CHARACTERISTICS (Tests made at 25°C unless otherwise specified)

Parameter	Test conditions	Symbol	Min	Typ	Max	Unit
Forward voltage	If = 100 mA	V_f		0.8	2.0	V
Reverse voltage	Ir = 10 μ A	BVR	3.0			V
Capacitance	Vr = 0 V, f = 1 MHz	C		70		pF
Fiber Coupled Power	If = 100 mA, 50 μ m core dia, .21 NA	P_{oc}	10 -20	20 -17		μ W dBm
Fiber Coupled Power	If = 100 mA, 62.5 μ m core dia, .28 NA	P_{oc}	20 -17	30 -15		μ W dBm
Total Optical Power	If = 100 mA	P_{out}	0.1	0.4		mW
Response Time	10%-90%, 1 V Prebias, If = 100 mA	t_r t_f		4 4	6 6	ns
Peak Wavelength	If = 100 mA	λ_p	1280	1310	1350	nm
Spectral Response	If = 100 mA	$\Delta\lambda$		145		nm
Electrical Bandwidth	If = 100 mA	BWE		85		MHz
Storage temperature			-55		+125	°C
Operating temperature			-40		+85	°C
Soldering temperature	Max. 10 seconds	T			+260	°C

NOTICE

The inherent design of this component causes it to be sensitive to electrostatic discharge (ESD). To prevent ESD-induced damage and/or degradation to equipment, take normal ESD precautions when handling this product.

Fiber Optic LAN Components 1310nm InGaAs PIN Detector

HFD8003-002/XBA

ORDER GUIDE

Catalog Listing	Description
HFE8500-020/XBA	1300nm SLED in ST PCB housing

MOUNTING DIMENSIONS

(for reference only)

Note: 1. The component is isolated from the connector.

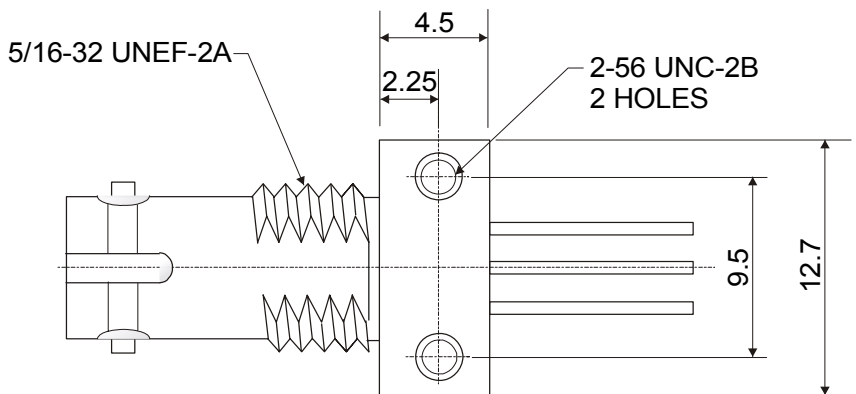
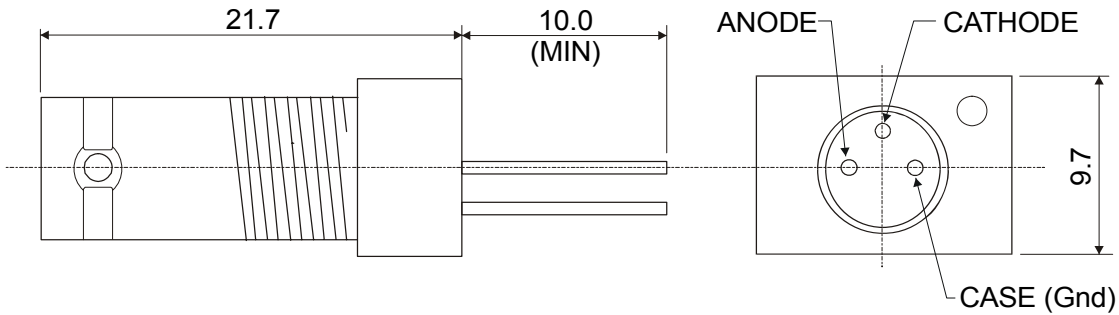

SALES AND SERVICE

Honeywell's serves its customers through a worldwide network of sales offices, representatives and distributors. For application assistance, current specifications, pricing or name of the nearest Authorized Distributor, contact a nearby sales office or:

1-815-235-6487 USA/Canada
 1-800-537-6945 International
 +44 (0)1698 481 481 UK

INTERNET

<http://www.honeywell.sensing.com>

Specifications may change at anytime and without notice. The information we supply is believed to be accurate and reliable as of this printing. However, we assume no responsibility for its use.

While we provide application assistance, personally and through our literature, it is up to the customer to determine the suitability of the product in the application.